



Triplex[®] Series

HIGH PRESSURE PUMPS

Flojet Triplex High Pressure Pumps are engineered to be the most advanced and reliable product available. The redesigned and improved pumps offer unequalled performance and life.

Flojet's unique three chamber design allows these pumps to operate at exceptional flow rates and pressures. With operating pressures up to 150 psi (10.3 bar) and self-priming capabilities. Flojet Triplex pumps are designed to be the most versatile pumps on the market today. They are the ideal solution for applications including spraying, misting, filtration, cooling, dispensing and pressure boosting.

The Flojet Triplex Series High Pressure Pumps are available now in 12V DC, 24V DC, 115V AC and 230V AC models, and being made from Santoprene[®]/EPDM and Santoprene[®]/Viton[®] makes them capable of handling a broad range of chemicals.

Features and Benefits

- Flow rates up to 1.4 GPM (5.3 LPM) and operating pressure of up to 150 psi (10.3 bar)
- Constructed from a selection of materials suitable for handling a broad range of chemicals
- Innovative bypass design
- Self priming up to 8ft (2.4m)
- Sealed motor
- Can run dry for extended periods of time without damage
- Coinjected molded diaphragm technology
- Consistent pressure over time



FLOJET
a xylem brand

Applications



• General Industrial

- Chemical washdown
- Evaporative Cooling Systems



• Agricultural

- Misting
- Spot Sprayers
- Boom Sprayers (to reach tree tops)



• Floor Care

- Carpet Extractors
- Carpet Cleaning



• Automotive

- Boost Cooling

Specifications

Motor Design	Perm. Magnet TENV (non-ventilated)
Voltage	12 V DC, 24V DC, 115V AC, 230V AC
Amp Draw	1.2 Amps Max for 115V AC
Pump Head Material	Glass Filled Nylon
Elastomers Diaphragm	Santoprene®
Check Valve	EPDM or Viton®
Maximum Flow Rate	1.4GPM (5.3 LPM)
Maximum Pressure	150 psi (10.3 bar)
Duty Cycle	Intermittent
Weight	7.6lbs (3.5kg)
Certifications	CE, NSF components
Port Size Inlet/outlet	3/8" NPTF

Head-Flow Chart Represents 115V AC Models

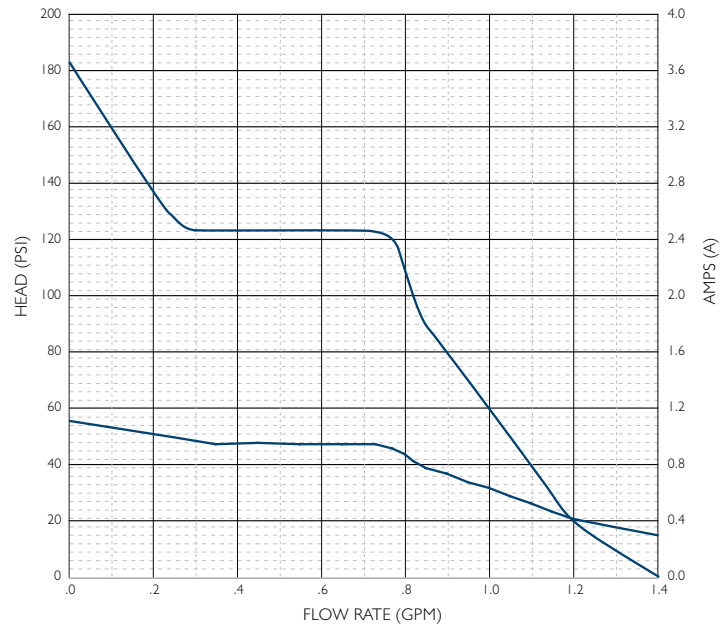

Dimensional Drawing

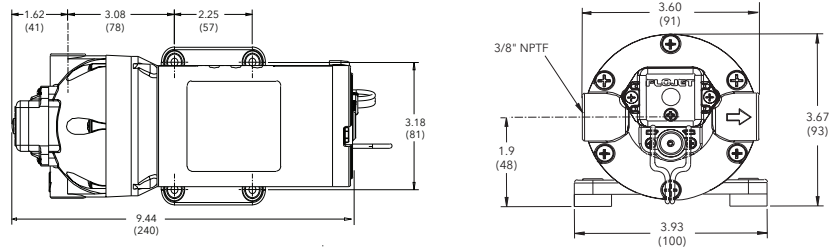

Std. Models	CE Models	Open Flow	Switch Pressure	Check Valve	Diaphragm	Voltage	Duty Cycle	Port Size
03811133	R3811133	1.4 GPM (5.3 LPM)	150 psi (10.3 bar)	Viton®	Santoprene®	12V DC	Intermittent	3/8" NPTF
03811143	R3811143	1.4 GPM (5.3 LPM)	150 psi (10.3 bar)	EPDM	Santoprene®	12V DC	Intermittent	3/8" NPTF
03811033	-	1.4 GPM (5.3 LPM)	150 psi (10.3 bar)	Viton®	Santoprene®	115V AC	Intermittent	3/8" NPTF
03811043	-	1.4 GPM (5.3 LPM)	150 psi (10.3 bar)	EPDM	Santoprene®	115V AC	Intermittent	3/8" NPTF
03811233	R3811233	1.4 GPM (5.3 LPM)	150 psi (10.3 bar)	Viton®	Santoprene®	230V AC	Intermittent	3/8" NPTF
03811243	R3811243	1.4 GPM (5.3 LPM)	150 psi (10.3 bar)	EPDM	Santoprene®	230V AC	Intermittent	3/8" NPTF

Santoprene® and Viton® are registered trademarks of DuPont Performance Elastomers.



Warranty: All products of the company are sold and all services of the company are offered subject to the company's warranty and terms and conditions of sale, copies of which will be furnished upon request. The information provided herein is for guidance only, it does not constitute a guarantee of the performance or specification of any individual product or component.

www.xyleminc.com

USA
Xylem, Inc.
Cape Ann Industrial Park
Gloucester, MA 01930
Tel: (978) 281-0440
Fax: (978) 283-2619

UK
Xylem, Inc.
Bingley Road, Hoddesdon
Hertfordshire EN11 0BU
Tel: +44 (0) 1992 450145
Fax: +44 (0) 1992 467132

GERMANY
Xylem, Inc.
Oststrasse 28
22844 Norderstedt
Tel: +49-40-53 53 73-0
Fax: +49-40-53 53 73-11

JAPAN
NHK Jabsco Company Ltd.
3-21-10, Shin-Yokohama
Kohoku-Ku, Yokohama, 222-0033
Tel: +81-045-475-8906
Fax: +81-045-477-1162

ITALY
Xylem, Inc.
Via Tommaseo, 6
20059 Vimercate, Milano
Tel: +39 039 685 2323
Fax: +39 039 666 307

INSTALLATION & SERVICE INFORMATION

FLOJET Triplex High Flow Series pumps are designed for a wide range of applications and are constructed from a selection of materials suitable for handling a broad range of chemicals. The Triplex High Flow pumps are self-priming and can run dry without harm. They are intended for intermittent duty cycles but can be run continuously for a short periods of time. The higher the duty cycle, the shorter the expected life of the pump. Typical uses include transfer, delivery, spraying, cooling, filtration, dispensing, and pressure boosting.

OPERATION

Allow pump to prime with discharge line (or spray valve) open, to avoid airlock. Built-in pressure switch will shut off pump automatically when discharge valve is closed and will restart pump when valve is opened. When pump runs out of liquid, it will continue to operate. Running dry will not damage the pump. Turn off manually.

DEMAND OPERATION (intermittent duty)

Pump models fitted with a pressure switch are known as demand pumps. The pressure switch is preset to shut off the pump motor automatically when a specific pressure is reached, such as in closed discharge conditions. The pressure switch turns the pump motor on automatically as the pressure drops, such as when the discharge is opened. Demand operation is considered an "intermittent duty" application. The maximum intermittent duty cycle is that which will cause the motor to reach its maximum thermal limits. Once the maximum thermal limit is reached, the motor must be allowed to settle to a lower (ideally ambient) temperature, before resuming operation. Running the pump at or near the maximum thermal limit for an extended period of time will shorten the life of the pump and may result in immediate pump failure. Demand pump models feature an integral pressure switch that automatically turns the pump off/on in response to open/closed discharge conditions.

BYPASS OPERATION (if equipped)

Models equipped with an external bypass system are designed to pump at high pressures while at low or high flow rates. Models equipped with bypass only must be turned off/on manually, or by an independent control device. Models equipped with a bypass only will continue to run until the power is manually turned off.

The Triplex High Pressure pumps are not recommended for continuous duty service due to limited motor brush life. Operation at lower pressures and temperatures, however, will extend overall pump service life.



SPECIFICATIONS

Pump Design:	3 chamber diaphragm
Motor Design:	Permanent magnet DC
Voltages:	12, 24 VDC
Pump Rating:	IP 54 (splash proof)
Amp Draw:	5 amps @ 10 psi for 12 VDC 3 amps @ 10 psi for 24 VDC 9 amps @ 10 psi for 12 VDC 6 amps @ 10 psi for 24 VDC 9 amps @ 40 psi for 12 VDC 6 amps @ 40 psi for 24 VDC
Pump Head:	Polypropylene
Elastomers:	
Diaphragm	Santoprene™
Check valves	Viton
Max. Flow Rate:	4 GPM (15.1 LPM)
Max. Pressure:	60 psi (4.1 bar) switch cutoff 50 psi (3.4 bar) max running pressure
Max. Liquid Temp:	40° F (4° C) Min* 140° F (60° C) Max*
Duty Cycle:	Intermittent**
Weight:	5.05 lbs (2.29 kg) max.
Wiring Options:	Standard 18 AWG leads
Port Size inlet / outlet:	3/4" (19 mm), 3/8" NPTF

* Consult factory for higher fluid temperature options

** Consult factory for continuous duty application

DIMENSIONAL DRAWINGS - inches (mm)

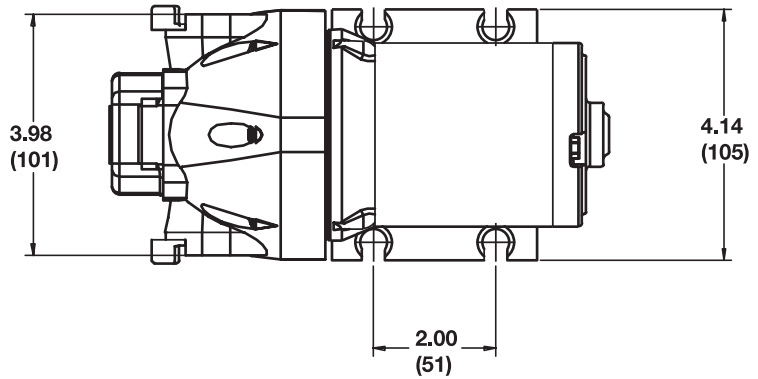
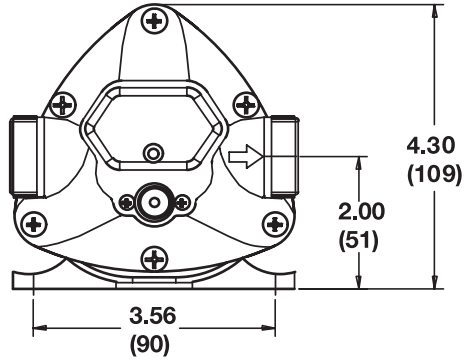

MOUNTING

FLOJET Triplex 3521 Series pumps are self-priming. They may be located several feet from the tank, above or below the liquid level (they are not submersible pumps).

PLUMBING

For best performance, flexible hose is recommended instead of rigid piping at the pump. Flojet Triplex 3521 Series ports are a push-in type retained by a "C" clip. To install the required ports move "C" clip forward to front of pump. Do not install pump such that plumbing causes excessive stress on either port.

It is essential that a 20 mesh (min.) strainer or filter be installed in the tank or in the pump inlet line to keep large foreign particles out of the system. The use of check valves in the plumbing system may interfere with the priming ability of the pump. Check valves, if used, must have cracking (opening) pressure of no more than 2 PSI.

WARNING

Risk of an electrical shock!



HEAD-FLOW CURVE (12 & 24 VDC)

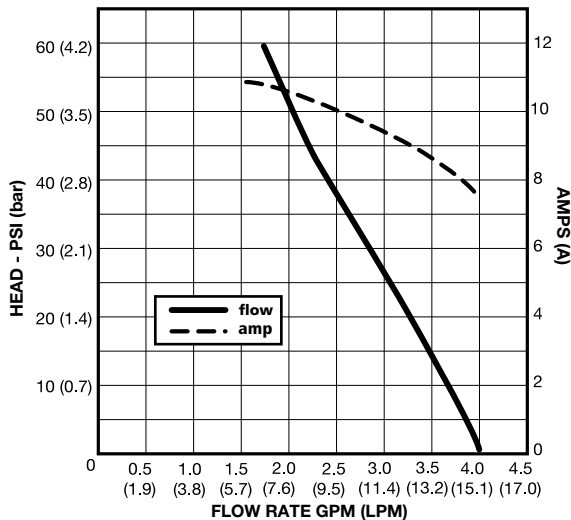

WIRING

Suggested wiring information is given as a reference only.

STEP 1

Determine the distance from the power source to the pump and then double the measurement. Wire gauge installation is determined on the entire run length, to the pump and back.

STEP 2

Connect to power supply lead (red (+)) to the positive (+) terminal on the battery or through a properly installed fuse/circuit breaker panel. Then run the length of wire to the pump, connecting the red wire through a switch appropriately rated to the pump's current requirements.

STEP 3

Route the wire so as not to create hazards in operation of the engine, movement of steering components or human traffic.

STEP 4

Connect the red lead to the red/orange lead on the pump.

STEP 5

Connect the black lead from the pump to the ground or negative power side (-) of the vessel.

STEP 6

Turn the system off when not in use for extended periods of time or when the water supply tank is empty.

STEP 7

After installation, check voltage at the pump motor. Voltage should be checked when pump is operating. Full voltage must be available at the pump motor at all times for proper pump operation and pump motor life.

IF YOU ARE NOT FAMILIAR WITH APPLICABLE ELECTRICAL STANDARDS, HAVE THE UNIT INSTALLED BY A QUALIFIED ELECTRICIAN



DO NOT USE TO PUMP FLAMMABLE FLUIDS, GASOLINE, KEROSENE, OR ANY FUEL OIL

DO NOT USE PUMP IN AN EXPLOSIVE ENVIRONMENT



EXPLODED VIEW DRAWING

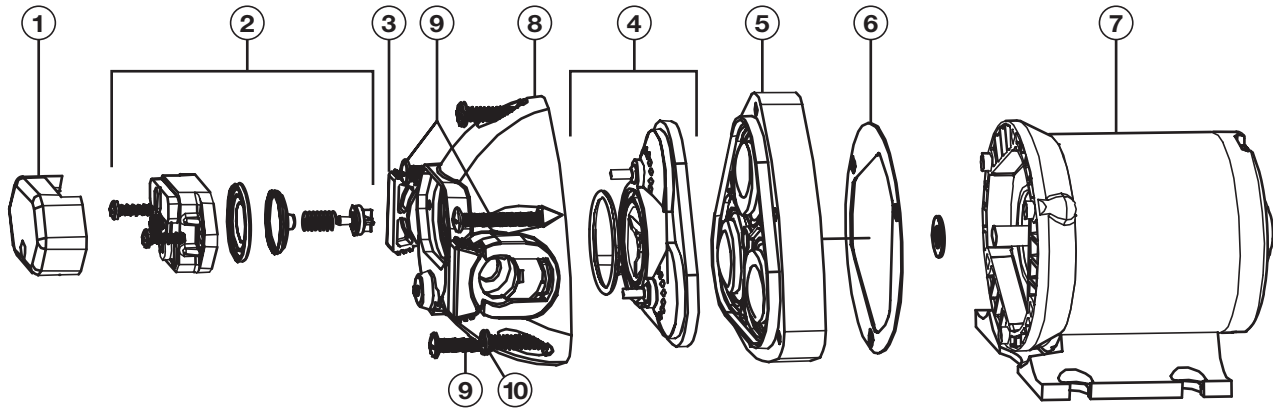

ITEM	DESCRIPTION	QUANTITY	PART NUMBER
1	Pressure Switch	1	02091060
2	Port Clips	1	21000407A
3	Valve Chamber Subassembly	1	20407021
4	Lower Housing Subassembly	1	20419015

DISASSEMBLE

Pump Housing

(For numbers, refer to exploded view)

1. Disconnect power to the pump motor (5).
2. Remove the pressure switch cover (1) and remove the two wire leads from the switch spade connectors.
3. Remove the six screws from the upper housing (7,8).
4. Remove the upper housing (6) from the check valve and diaphragm/lower housing assemblies (3,4).

Check Valve Assembly

(To replace check valve only follow steps 1 through 6)

5. The check valve chamber and o-ring are located on the diaphragm/lower housing assembly (3,4).
6. Remove the check valve chamber subassembly (3) from the diaphragm/lower housing subassembly (pull the valve chamber from the diaphragm) (3,4).

Diaphragm/Cam/Lower Housing Assembly

7. Remove the diaphragm/lower housing assembly (3,4) from the motor front end bell adapter.

Motor Replacement

8. To replace the motor only, follow steps 1 and 2, then disconnect 3 screws (7), and pull the pump head out. Replace the motor with washer and gasket (9).

REASSEMBLE

Pressure Switch Assembly

1. Install the switch diaphragm into upper housing (6).
Note: Check the old diaphragm for the material mark located in the center of the new diaphragms. V is for VITON, and E is for EPDM. Select the correct material for the installation.
2. Install the switch body over the diaphragm, align the screw holes and install the two mounting screws.
3. Reinstall the two wires onto the spade connectors, then install the switch cover and screw.

Check Valve Assembly

4. Install the o-ring into the o-ring groove located on the discharge side of the check valve chamber assembly (3).
5. Install the check valve chamber assembly into the diaphragm, thus aligning the check valve chamber with the diaphragm seal walls (push in to secure to the diaphragm).

Upper Housing Assembly

6. With the check valve chamber sub assembly (3,4) installed on the diaphragm, place the upper housing assembly (6) onto the pre-assembled lower housing sub assembly (3,4).
7. Align the cam with the motor "D" shaft and motor list, then slide the cam onto the motor shaft (lube the motor shaft with a small amount of light grease).
8. Check the discharge location (see arrow on front of port) for correct port orientation (discharge right is the standard position).
9. Install the six pump head screws (7,8) through the upper housing (6), 3 screws (8) will engage to lower housing (4). The other 3 screws (7) will go through the lower housing (5) into the front end bell assembly aligning the three pins on the front end bell with the 3 holes on the lower housing and tighten securely.

Motor Assembly

10. Install the pump head by following steps 6 through 9.

PUMP TROUBLESHOOTING CHART

Failure to prime - motor operates, but no pump discharge

- Restricted intake or discharge line. Open all line valves, check for "jammed" check valves, and clean clogged lines.
- Air leak in intake line.
- Punctured pump diaphragm.
- Defective pump check valves.
- Crack in pump housing.
- Debris in check valves.
- Missing or damaged o-ring of control valve chamber.
- Pinched/kinked hose.
- Damaged inlet or outlet check valve.

Motor fails to turn on

- Pump or equipment not plugged in electrically.
- Loose wiring connection.
- Pressure switch failure.
- Defective motor or rectifier.
- Frozen cam/bearing.

Pump fails to turn off after discharge valves are closed

- Depletion of available liquid supply.
- Punctured pump diaphragm.
- Discharge line leak.
- Defective pressure switch.
- Insufficient voltage to pump.
- Debris in check valves.

Low flow and pressure

- Defective check valves (most cases).
- Air leak at pump intake.
- Accumulation of debris inside pump and plumbing.
- Worn pump bearing (excessive noise).
- Punctured pump diaphragm.
- Defective rectifier or motor.
- Insufficient voltage to pump.

Pulsating flow - pump cycling on and off

- Restricted pump delivery. Check discharge lines, fittings, valves and spray nozzles for clogging or undersizing.

AVAILABLE MODELS

Visit www.flojet.com for a complete list model numbers.

PREVENTATIVE MAINTENANCE TIPS

If pumping a liquid other than water, the pump should be flushed with water (if applicable) after each use. Sealers and Teflon tape acting as a lubricant can cause cracked housings or stripped threads due to over-tightening. Care should be used when applying sealers; the tape may enter the pump, thus inhibiting valve action and causing no prime or no shut-off conditions. Failures due to foreign debris are not covered under warranty.

Before freezing conditions occur, the pump must be liquid free or winterized with proper anti-freezing chemicals. If mounting the pump in an outdoor environment, the pump should be shielded from water, dust, sunlight, and washdown spray. Do not assume chemical compatibility. If the fluid is improperly matched to the pump's elastomers, the pump may fail to prime, have low pressures, or the pressure switch may not shut off. Contact your supplier for advice.

PRODUCT WARRANTY

FLOJET warrants this product to be free of defects in material and/or workmanship for a period of one year after purchase by the customer from **FLOJET**. During this one year warranty period, **FLOJET** will, at its option and at no charge to the customer, repair or replace this product if found defective. No product will be accepted for return without a return material authorization number. All return goods must be shipped with transportation charges prepaid. This is only a summary of our Limited Warranty. For a copy of our complete warranty, please request Form No. 100-101.

SERVICE KITS

Kits are readily available to repair standard Triplex High Pressure Series pumps. To insure that the correct kits are received, the model number and all name plate data must be included with the order. Contact a **FLOJET** distributor to order the necessary repair kits.

RETURN PROCEDURE

Prior to returning any product to **FLOJET**, call customer service for an authorization number. This number must be written on the outside of the shipping package. Place a note inside the package with an explanation for return as well as the authorization number. Include your name, address and phone number. MSDS required.

www.xylemflowcontrol.com

FLOJET
a xylem brand

U.S.A.
Flojet
666 E. Dyer Rd.
Santa Ana, CA 92705
Phone: 949.608.3900
Fax: 949.608.3887

UNITED KINGDOM
Flojet
Bingley Road, Hoddesdon
Hertfordshire EN11 0BU
Tel: +44 (0) 1992 450145
Fax: +44 (0) 1992 467132

CANADA
Fluid Products Canada
55 Royal Road
Guelph, Ontario N1H 1T1
Tel: 519 821.1900
Fax: 519 821.2569

JAPAN
NHK Jabsco Company Ltd.
3-21-10, Shin-Yokohama
Kohoku-Ku, Yokohama, 222
Tel: 045.475.8906
Fax: 045.475.8908

GERMANY
Jabsco GmbH
Oststrasse 28
22840 Norderstedt
Tel: +49-40-53 53 73 -0
Fax: +49-40-53 53 73 -11

ITALY
Jabsco Marine Italia
Via Tommaseo, 6
20059 Vimercate, Milano
Tel: +39 039 685 2323
Fax: +39 039 666 307

INSTALLATION & SERVICE INFORMATION

FLOJET Triplex Low Pressure Series pumps are designed for a wide range of applications and are constructed from a selection of materials suitable for handling a broad range of chemicals. The Triplex Low Pressure diaphragm pumps are self-priming and can run dry without harm. They are intended for intermittent duty cycles but can be run continuously for short periods of time. The higher the duty cycle, the shorter the expected life of the pump. Typical uses include transfer, delivery, spraying, cooling filtration, dispensing, and pressure boosting.

OPERATION

To start and prime the pump, the discharge line must be opened to allow trapped air to escape, thus avoiding the potential of airlock. For demand models, the pressure switch will shut off the pump automatically when the discharge valve is closed and the pressure has risen to the switch OFF set point. The pressure switch will restart the pump when a valve is opened and the discharge line pressure drops to the ON set point of the pressure switch. For bypass models, apply power to the pump, and open the discharge valve to expel air in the line.

DEMAND OPERATION (intermittent duty)

Pump models fitted with a pressure switch are known as demand pumps. The pressure switch is preset to shut off the pump motor automatically when a specific pressure is reached, such as in closed discharge conditions. The pressure switch turns the pump motor on automatically as the pressure drops, such as when the discharge is opened. Demand operation is considered an "intermittent duty" application. The maximum intermittent duty cycle is that which will cause the motor to reach its maximum thermal limits. Once the maximum thermal limit is reached, the motor must be allowed to settle to a lower (ideally ambient) temperature, before resuming operation. Running the pump at or near the maximum thermal limit for an extended period of time will shorten the life of the pump and may result in immediate pump failure. Demand pump models feature an integral pressure switch that automatically turns the pump off/on in response to open/closed discharge conditions.

BYPASS OPERATION (if equipped)

Models equipped with an external bypass system are designed to pump at high pressures while at low or high flow rates. Models equipped with bypass only must be turned off/on manually, or by an independent control device. Models equipped with a bypass only will continue to run until the power is manually turned off.

The Triplex High Pressure pumps are not recommended for continuous duty service due to limited motor brush life. Operation at lower pressures and temperatures, however, will extend overall pump service life.



SPECIFICATIONS

Pump Design:	Motor operated 3 chamber diaphragm
Motor Design:	Permanent magnet DC TENV (Non-Ventilated) Rectified (PmDC) AC
Voltages:	12 VDC, 24 VDC 115 VAC, 230 VAC
Cycles:	50/60 Hz
Amp Draw:	8 amps max. for 12 VDC 0.65 amps max for 115/230 VAC
Pump Head:	Reinforced Polypropylene
Elastomers:	
Diaphragm	Santoprene™
Check valves	EPDM or Viton
Max. Flow Rate:	2.0 GPM (7.6 LPM)
Max. Pressure:	50 psi (3.4 bar)
Liquid Temperature:	40° F (4° C) Min* 140° F (60° C) Max*
Duty Cycle:	Intermittent
Weight:	3.4 lbs (1.5 kg)
Wiring Options:	Standard 18" (46 cm) leads 6 ft. (2 m) cord available for AC
Certifications:	AC, UL, CE, NSF Components
Port Size inlet / outlet:	3/8" NPTF

* Consult factory for fluid temperature options.

DIMENSIONAL DRAWINGS

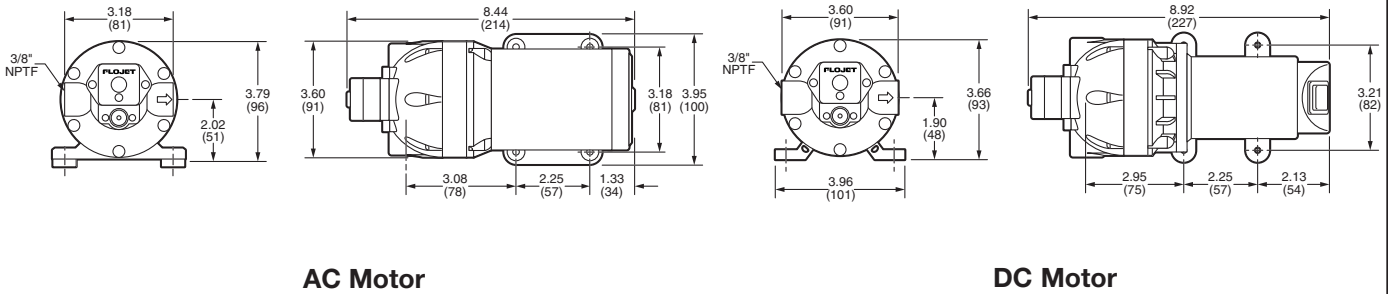

AC Motor

DC Motor

MOUNTING

FLOJET Triplex Low Pressure Series pumps are self-priming. Vertical prime may vary depending on the fluid viscosity, suction tube size, foot valve, and pump configuration. The pump should be mounted in a dry and adequately ventilated area. If mounted within an enclosure, provisions to cool the motor may be necessary. When wiring electrically driven pumps, follow all electrical and safety codes, as well as the most recent National Electrical Code (NEC) and Occupational Safety and Health Act (OSHA). Make certain the power source conforms to the pump voltage, and be sure all power is disconnected before installation. The pump should be wired into an individual (dedicated) circuit, controlled with an UL/C-UL certified double pole switch rated at or above the fuse ampere indicated on the pump motor label. On 115/230-volt AC pumps, the black wire lead is live or common, the white lead wire is neutral and the green/yellow is ground. On 230-volt AC pumps the brown wire lead is live or common, the blue wire is neutral and the green/yellow is ground. On 12 and 24 volt pumps the red lead is positive and should be connected to the battery plus (+) terminal. The black lead is ground and should be connected to the battery minus (-) terminal. Use T6 AWG wire minimum. Use a fuse to protect the system wiring and components. Improper duty cycle and/or rapid start/stop conditions caused by undersized spray nozzles will cause the internal thermal breaker (if equipped) to trip, or can cause premature motor failure due to excessive heat.

WARNING

Risk of an electrical shock!



Horizontal Position

Vertical Position

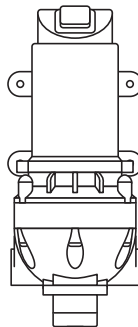
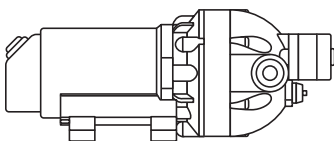

PLUMBING

Use flexible hose with the correct pressure rating that is compatible with the fluid to be pumped. Tubing should be a minimum of 3/8" (10 mm) ID and at least 20 inches (51 cm) in length to avoid excess stress on the pump ports. Do not crimp or kink the tubing. The pump head may be rotated in 120° increments. Or reverse the flow (180°) by using other optional lower housing to simplify plumbing.

FLOJET does not recommend the use of metal fittings; standard plastic male and female threaded fittings can be acquired at commercial plumbing supply stores.

FLOJET also distributes plastic barb fittings through our distributors (form no. F100-001). The use of check valves in the plumbing system could interfere with the priming ability of the pump. If a check valve is installed in the plumbing, it must have a cracking pressure of no more than 2 PSI (.14 bar). Use of a minimum 40-mesh strainer or filter in the pump inlet line will prevent foreign debris from entering the system. Failures due to foreign debris entering the pump will not be covered under the limited warranty.

Note: Inlet pressure must not exceed 30 PSI (2.1 bar) maximum.

Flow Curve 12 VDC

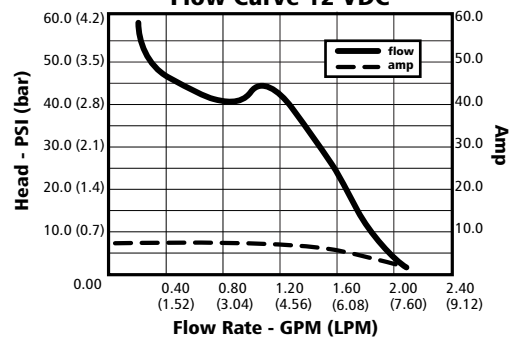

Flow Curve 115 / 230 VAC

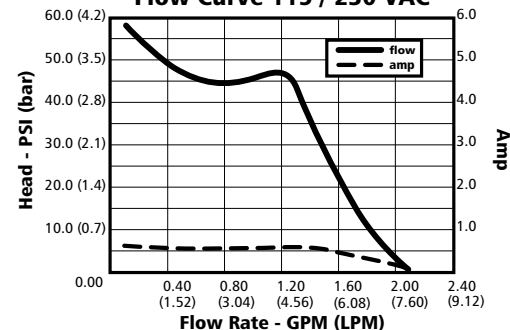

DO NOT USE TO PUMP FLAMMABLE FLUIDS, GASOLINE, KEROSENE, OR ANY FUEL OIL
DO NOT USE PUMP IN AN EXPLOSIVE ENVIRONMENT



EXPLODED VIEW DRAWINGS

PUMP ASSEMBLY

ITEM	DESCRIPTION
1	Screws (6)
2	Upper Housing with switch
3	Check Valve Assembly with O-Ring
4	Lower Housing Assembly
5	Motor Adapter Assembly
6	Motor Assembly
7	Mounting Feet (4)

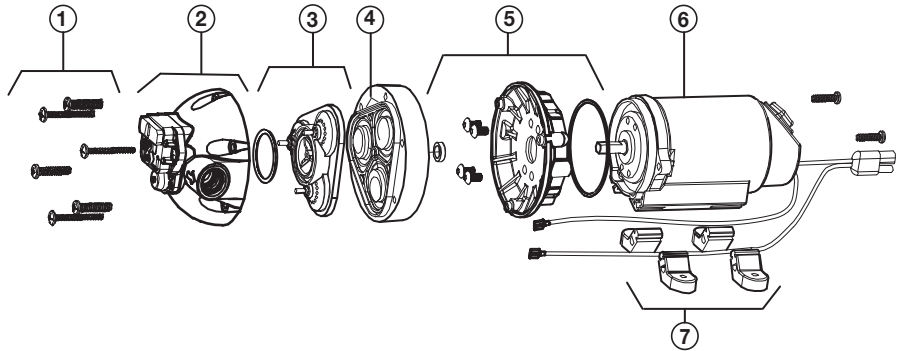

BYPASS - UPPER HOUSING

ITEM	DESCRIPTION
1	Upper Housing Viton SW60
2	Stainless Steel Spring
3	Pulsation Dampener
4	Diaphragm

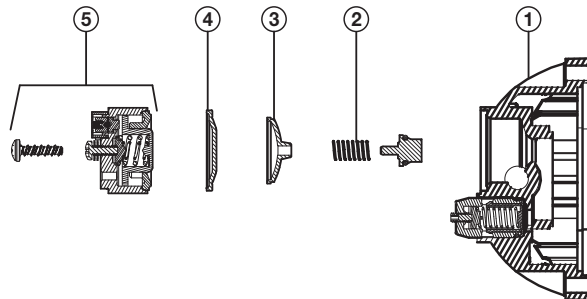

DISASSEMBLE

Pump Housing

1. Disconnect power to the pump motor.
2. Remove the pressure switch cover (not shown) and remove the two wire leads from the switch spade connectors.
3. Remove the six screws (1) from the upper housing (2).
4. Remove the upper housing from the check valve and diaphragm/lower housing assemblies (3 & 4).

Check Valve Assembly (3)

(To replace check valve only follow steps 1 through 6)

5. The check valve housing and o-ring (3) are located on the diaphragm/lower housing assembly (4).

6. Remove the check valve (3) from the diaphragm/lower housing subassembly (4) (pull valve body from the diaphragm).

Diaphragm/Cam/Lower Housing Assembly (4)

7. Remove the diaphragm/lower housing assembly (4) from the motor adapter assembly (5).

Motor Replacement (6)

8. To replace the motor only, follow steps 1 through 7.
9. Remove the motor adapter assembly (5) from the old motor (it may require a 3 mm Allen wrench).
10. Remove the four alien head screws from the motor adapter and remove the adapter and o-ring.

REASSEMBLE

Pressure Switch Assembly (not shown)

1. Install the switch diaphragm into upper housing. Note: Check the old diaphragm for the material mark located in the center of the new diaphragms. V is for VITON, B is for BUNA, and E is for EPDM. Select the correct material for the installation.
2. Install the switch body over the diaphragm, align the screw holes and install the two mounting screws.
3. Reinstall the two wires onto the spade connectors, then install the switch cover and screw.

Check Valve Assembly (3)

4. Install the o-ring into the o-ring groove located on the discharge side of the check valve chamber assembly (3).
5. Install the check valve chamber assembly into the diaphragm (4), thus aligning the check valve body with the diaphragm seal walls (push in to secure to the diaphragm).

Upper Housing Assembly (2)

6. With the check valve assembly installed on the diaphragm, place the upper housing assembly onto the pre-assembled lower housing diaphragm/cam assembly (4).
7. Align the cam with the motor "D" shaft, then slide the cam and pump head assembly onto the motor shaft (6) (lube the motor shaft with a small amount of light grease).

8. Check the discharge location (see arrow on front of port) for correct port orientation (discharge right is the standard position).

9. Install the six pump head screws (1) through the upper housing and through the lower housing into the front end bell assembly (2, 4 & 5) aligning the three pins on the motor adapter with the upper housing and tighten securely (torque to 25 inch-pounds).

Motor Assembly

10. Install the o-ring into the motor adapter assembly (5).
11. Install the motor adapter assembly onto the new motor by aligning the adapter with the motor housing and screw bosses.
12. Install the four (3 mm) Allen screws through the adapter and into the motor and secure (5 & 6). (Apply a thin layer of screw Loctite 271 to secure these screws.)
13. Install the pump head by following steps 6 through 9.
14. AC Motors do not have a separate Motor Adapter.

PUMP TROUBLESHOOTING CHART

Failure to prime - motor operates, but no pump discharge

- Restricted intake or discharge line. Open all line valves, check for "jammed" check valves, and clean clogged lines.
- Air leak in intake line.
- Punctured pump diaphragm.
- Defective pump check valve.
- Crack in pump housing.
- Debris in check valves.
- Missing or damaged o-ring of control valve chamber.
- Pinched/kinked hose.
- Damaged inlet or outlet check valve.

Motor fails to turn on

- Pump or equipment not plugged in electrically.
- Loose wiring connection.
- Pressure switch failure.
- Defective motor or rectifier.
- Frozen cam/bearing.

Pump fails to turn off after discharge valves are closed

- Depletion of available liquid supply.
- Punctured pump diaphragm.
- Discharge line leak.
- Defective pressure switch.
- Insufficient voltage to pump.
- Debris in check valves.

Low flow and pressure

- Defective check valves (most cases).
- Air leak at pump intake.
- Accumulation of debris inside pump and plumbing.
- Worn pump bearing (excessive noise).
- Punctured pump diaphragm.
- Defective rectifier or motor.
- Insufficient voltage to pump.

Pulsating flow - pump cycling on and off

- Restricted pump delivery. Check discharge lines, fittings, valves and spray nozzles for clogging or undersizing.

AVAILABLE MODELS

Visit www.flojet.com for a complete list model numbers.

PREVENTATIVE MAINTENANCE TIPS

If pumping a liquid other than water, the pump should be flushed with water (if applicable) after each use. Sealers and Teflon tape acting as a lubricant can cause cracked housings or stripped threads due to over-tightening. Care should be used when applying sealers; the tape may enter the pump, thus inhibiting valve action and causing no prime or no shut-off conditions. Failures due to foreign debris are not covered under warranty.

Before freezing conditions occur, the pump must be liquid free or winterized with proper anti-freezing chemicals. If mounting the pump in an outdoor environment, the pump should be shielded from water, dust, sunlight, and washdown spray. Do not assume chemical compatibility. If the fluid is improperly matched to the pump's elastomers, the pump may fail to prime, have low pressures, or the pressure switch may not shut off. Contact your supplier for advice.

PRODUCT WARRANTY

FLOJET warrants this product to be free of defects in material and/or workmanship for a period of one year after purchase by the customer from **FLOJET**. During this one year warranty period, **FLOJET** will, at its option and at no charge to the customer, repair or replace this product if found defective. No product will be accepted for return without a return material authorization number. All return goods must be shipped with transportation charges prepaid. This is only a summary of our Limited Warranty. For a copy of our complete warranty, please request Form No. 100-101.

SERVICE KITS

Kits are readily available to repair standard Triplex High Pressure Series pumps. To insure that the correct kits are received, the model number and all name plate data must be included with the order. Contact a **FLOJET** distributor to order the necessary repair kits.

RETURN PROCEDURE

Prior to returning any product to **FLOJET**, call customer service for an authorization number. This number must be written on the outside of the shipping package. Place a note inside the package with an explanation for return as well as the authorization number. Include your name, address and phone number. MSDS required.

www.xylemflowcontrol.com

FLOJET
a xylem brand

U.S.A. Flojet 666 E. Dyer Rd. Santa Ana, CA 92705 Phone: 949.608.3900 Fax: 949.608.3887	UNITED KINGDOM Flojet Bingley Road, Hoddesdon Hertfordshire EN11 0BU Tel: +44 (0) 1992 450145 Fax: +44 (0) 1992 467132	CANADA Fluid Products Canada 55 Royal Road Guelph, Ontario N1H 1T1 Tel: 519 821.1900 Fax: 519 821.2569	JAPAN NHK Jabsco Company Ltd. 3-21-10, Shin-Yokohama Kohoku-Ku, Yokohama, 222 Tel: 045.475.8906 Fax: 045.475.8908	GERMANY Jabsco GmbH Oststrasse 28 22840 Norderstedt Tel: +49-40-53 53 73 -0 Fax: +49-40-53 53 73 -11	ITALY Jabsco Marine Italia Via Tommaseo, 6 20059 Vimercate, Milano Tel: +39 039 685 2323 Fax: +39 039 666 307
--	---	---	--	---	--

QUAD PUMP



-
- Flojet 4000 Delivers Flows up to 5.0 GPM (19.0 *ℓ/min.*)
 - Built-in Pressure Switch Automatically Starts and Stops Pump Instantaneously
 - Can Run Dry Without Damage
 - Excellent Self-priming Capability
 - Powerful Magnet Motor with Low Current Draw
 - Plug-in Ports for Easy Installation
-

FLOJET

SPECIAL FEATURES

FLOJET 4000 delivers up to 40 PSI 2.8 (bar) working pressure. Built-in pressure switch automatically starts and stops pump instantaneously when discharge valve is opened and closed. Compact design and plug-in port fittings make installation easy. Can run dry without damage and handle liquids up to 130°F (54°C). Quad Diaphragm Design eliminates troublesome shaft seal. No metal contact with liquid being pumped. Ball bearing drive throughout pump and motor assures longer pump life. Excellent self-priming capability. Pump may be located above the liquid level. Powerful, permanent magnet motor with low current draw and long life brushes.

PUMP PERFORMANCE

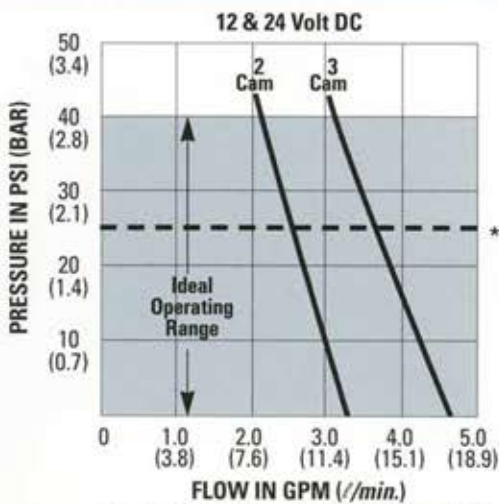

* Continuous Duty Max Pressure For No Switch 3 Cam Models.

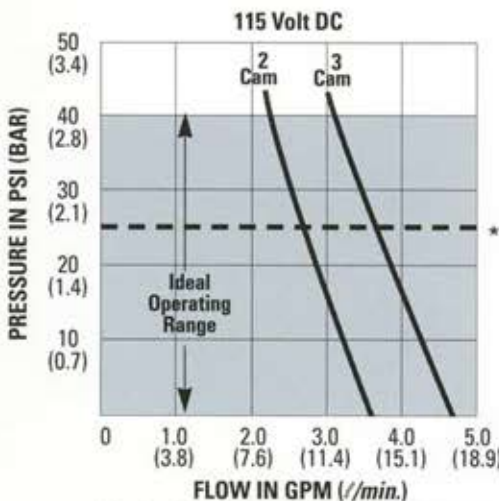

* Continuous Duty Max Pressure For No Switch 3 Cam Models.

SPECIFICATIONS

Flow Rate	3.5 to 5.0 GPM (13.2 and 18.9 <i>l/min.</i>) Nominal
Pump Design	Diaphragm
Shaft Seal	None
Motor	Permanent Magnet Motor
Standard	TEFC (fan-cooled)
Voltage	12 & 24 Volt DC, 115 & 230 Volt AC
Cycle	50/60 hertz for AC Models
Current	
12 Volt	14.0 amp max.
24 Volt	0.7 amp max.
115 Volt	1.5 amp max.
230 Volt	0.75 amp max.
Pressure Switch Setting	45 PSI (3.2 bar) cut out 30 PSI (2.1 bar) cut in
Maximum Operating Pressure	40 PSI (2.8 bar) (Demand Pumps only)
Maximum Fluid Temperature	130°F (54°C)
Self-Priming	Up to 8 ft. (2.4 m) Vertical Height
Ports	Plug-In Ports 1/2" or 3/4" Hose Barb Standard (Consult Factory for other type of Port Fittings)
Wetted Parts	
Housing	Modified Polypropylene - Standard
Elastomers	Santoprene® and Buna - Standard
Net Weight	4 lbs. (2 kg)

® A Registered trademark of E.I. duPont de Nemours & Co. Inc.

STANDARD MODELS		CAM NO.
115 VOLT 3.5 GPM 1/2" HOSE BARB		
4300-042	Santo/EPDM, Switch at 45 PSI	2
4100-500	Santo/EPDM, No Pressure Switch	2
115 VOLT 5.0 GPM 3/4" HOSE BARB		
4300-043	Santo/EPDM, Switch at 45 PSI	3
4100-512	Santo/Viton, No Pressure Switch	3
12 VOLT 3.5 GPM 1/2" HOSE BARB		
4300-142	Santo/EPDM, Switch at 45 PSI	2
4100-505	Santo/EPDM, No Pressure Switch	2
12 VOLT 5.0 GPM 3/4" HOSE BARB		
4300-143	Santo/EPDM, Switch at 45 PSI	3
4100-143	Santo/EPDM, No Pressure Switch	3

Note: All Motors Are Fan Cooled With A Thermo Switch Used On All Non-Pressure Switch Models.

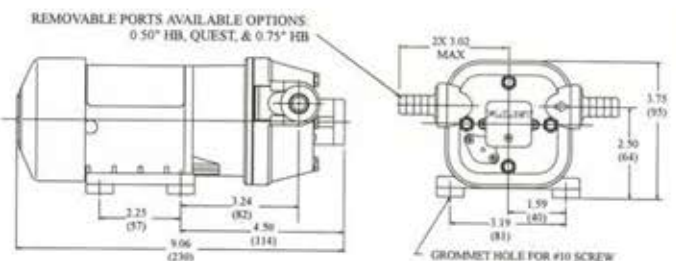

Flojet

For further information, contact your FLOJET representative, or write to:

FLOJET
20 Icon • Foothill Ranch, CA 92610
Tel: 949-859-4945
1-800-2 FLOJET
Fax: 1-949-859-1153

FLOJET (EUROPE) LTD.
Unit 1, Avant Business Centre
Denbigh West Industrial Estate
Milton Keynes, Bucks, England MK1 1DL
Tel: 44-1908-370088 • Fax: 44-1908-373731



VersiJet™ Series

HIGH CAPACITY PUMPS

The New VersiJet High Capacity Pumps are backed by Flojet's diaphragm pump technology, a brand enjoying over 35 years of operational excellence. The innovative new and improved five chamber design offers unequalled performance, capable of handling up to 6 GPM at open flow.

With pressures up to 70 psi (4.8 bar), self-priming capabilities up to 10 feet (wetted), and heavier duty brushes extending the operating life up to 50% longer than existing Flojet Quad Series diaphragm pumps, the Flojet VersiJet pumps are designed to be the most reliable and versatile pumps on the market today. These pumps are the ideal solution for applications including spraying, fluid transfer, filtration, cooling, dispensing and pressure boosting.

The Flojet VersiJet Series High Capacity Pumps are made from Santoprene®/EPDM and Santoprene®/Viton®, resulting in true compatibility with most harsh and abrasive chemicals.

Features and Benefits

- Multiple sizing options, providing flow up to 6 GPM (22.7 LPM) and pressure up to 70 psi (4.8 bar)
- Robust material selection, suitable for handling a broad range of chemicals
- Co-injected molded diaphragm technology, ensuring run dry capability, extending the life of the pump upwards of 50%
- IPX6 rated pump with a sealed motor and pressure switch, providing years of dependable reliability
- Self priming, accommodating up to 10ft (3m) (wetted)



FLOJET
a xylem brand

Applications



• General Industrial

- Chemical Washdown
- Evaporative Cooling Systems
- Fluid Transfer



• Agricultural

- Fogging / Misting
- Boom Sprayers (to reach tree tops)



• Automotive

- DEF (Diesel Exhaust Fluid) Transfer
- Fluid Exchange Exhaust Cleaning

Head-Flow Chart

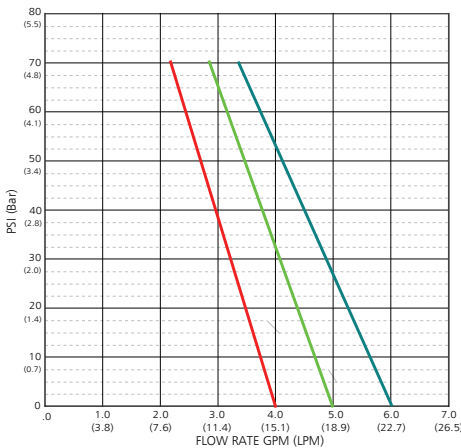

4.0 GPM

PSI	GPM	AMPS
0	4.0	3.6
10	3.8	5.0
20	3.5	6.4
30	3.3	7.8
40	3.0	9.0
50	2.7	10.1
60	2.5	11.1
70	2.2	12.0

5.0 GPM

PSI	GPM	AMPS
0	5.0	5.5
10	4.7	7.9
20	4.4	9.5
30	4.1	10.9
40	3.8	12.1
50	3.4	13.1
60	3.1	14.0
70	2.8	14.7

6.0 GPM

PSI	GPM	AMPS
0	6.0	7.4
10	5.7	8.3
20	5.3	10.1
30	4.9	11.6
40	4.5	13.0
50	4.1	14.4
60	3.7	15.2
70	3.3	15.6

15.1 LPM

PSI	GPM	AMPS
0	15.1	3.6
0.7	14.2	5.0
1.4	13.3	6.5
2.0	12.3	7.8
2.8	11.3	9.0
3.4	10.3	10.1
4.1	9.3	11.1
4.8	8.3	12.0

18.9 LPM

PSI	GPM	AMPS
0	18.9	5.5
0.7	18.1	7.9
1.4	16.8	9.5
2.0	15.5	10.9
2.8	14.2	12.1
3.4	13.0	13.1
4.1	11.9	14.0
4.8	10.6	14.7

22.7 LPM

PSI	GPM	AMPS
0	22.7	7.4
0.7	21.4	8.3
1.4	20.0	10.1
2.0	18.5	11.6
2.8	17.0	13.0
3.4	15.5	14.4
4.1	14.0	15.2
4.8	12.5	15.6

Note: Pressure, flow and Amp data is tested at 12.8 volts.
See Flojet R7300 series for 7.0 GPM models.

Specifications

Motor Design	Perm. Magnet TENV (non-ventilated)
Voltage Options	12 VDC, 24 VDC, 115 VAC, 230 VAC
Pump Head Material	Glass Filled Nylon
Diaphragm Elastomer	Santoprene®
Check Valve Materials	Glass Filled Nylon, EPDM or Viton®
Maximum Flow Rate	6.0 GPM (22.7 LPM)
Maximum Pressure	70 psi (4.8 bar)
Duty Cycle	Intermittent
Weight	7.6lbs (3.5kg)
Certifications	CE, RoHs, IPX6
Standard Port Size Inlet/Outlet	1/2" HB (4 GPM), 3/4" HB (5 and 6 GPM)

Dimensional Drawing - 5 GPM / 6 GPM models

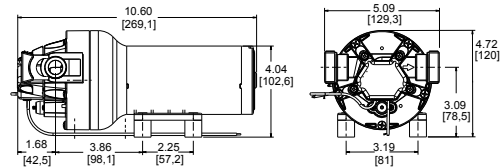

Note: 4 GPM model overall length 9.91in (251.7mm). All other dimensions are the same as the 5 GPM / 6 GPM models. Dimensions in inches [mm]

Part No.	Volts	GPM (LPM)	Switch PSI (Bar)	Diaphragm	Check Valve
R8400144	12	4 (15.1)	70 (4.8)	Santo	EPDM
R8400344	24	4 (15.1)	70 (4.8)	Santo	EPDM
R8400044	115	4 (15.1)	70 (4.8)	Santo	EPDM
R8400244	230	4 (15.1)	70 (4.8)	Santo	EPDM
R8400134	12	4 (15.1)	70 (4.8)	Santo	Viton
R8400334	24	4 (15.1)	70 (4.8)	Santo	Viton
R8400034	115	4 (15.1)	70 (4.8)	Santo	Viton
R8400234	230	4 (15.1)	70 (4.8)	Santo	Viton

Part No.	Volts	GPM (LPM)	Switch PSI (Bar)	Diaphragm	Check Valve
R8500144	12	5 (18.9)	70 (4.8)	Santo	EPDM
R8500344	24	5 (18.9)	70 (4.8)	Santo	EPDM
R8500044	115	5 (18.9)	70 (4.8)	Santo	EPDM
R8500244	230	5 (18.9)	70 (4.8)	Santo	EPDM
R8500134	12	5 (18.9)	70 (4.8)	Santo	Viton
R8500334	24	5 (18.9)	70 (4.8)	Santo	Viton
R8500034	115	5 (18.9)	70 (4.8)	Santo	Viton
R8500234	230	5 (18.9)	70 (4.8)	Santo	Viton

Part No.	Volts	GPM (LPM)	Switch PSI (Bar)	Diaphragm	Check Valve
R8600144	12	6 (22.7)	70 (4.8)	Santo	EPDM
R8600344	24	6 (22.7)	70 (4.8)	Santo	EPDM
R8600044	115	6 (22.7)	70 (4.8)	Santo	EPDM
R8600244	230	6 (22.7)	70 (4.8)	Santo	EPDM
R8600134	12	6 (22.7)	70 (4.8)	Santo	Viton
R8600334	24	6 (22.7)	70 (4.8)	Santo	Viton
R8600034	115	6 (22.7)	70 (4.8)	Santo	Viton
R8600234	230	6 (22.7)	70 (4.8)	Santo	Viton

Santoprene® is a registered trademark of Monsanto.

Viton® is registered trademark of DuPont Performance Elastomers.



Warranty: All products of the company are sold and all services of the company are offered subject to the company's warranty and terms and conditions of sale, copies of which will be furnished upon request. The information provided herein is for guidance only, it does not constitute a guarantee of the performance or specification of any individual product or component.

www.xyleminc.com

USA
Xylem Inc.
100 Cummings Center Drive
Suite 535-N, Beverly, MA 01915
Tel: +1 978 281-0440
Fax: +1 978 283-2619

UK
Xylem Inc.
Bingley Road, Hoddesdon
Hertfordshire EN11 0BU
Tel: +44 (0) 1992 450145
Fax: +44 (0) 1992 467132

GERMANY
Xylem Inc.
Oststrasse 28
22844 Norderstedt
Tel: +49-40-53 53 73-0
Fax: +49-40-53 53 73-11

CHINA
Xylem Inc.
30/F, Tower A Hongqiao City
Center of Shanghai 100 Zunyi
Road, Shanghai 200051, China
Tel: +(86) 21 2208 2888
Fax: +(86) 21 2208 2999

ITALY
Xylem Inc.
Via Tommaseo, 6
20059 Vimercate, Milano
Tel: +39 039 685 2323
Fax: +39 039 666 307